

## Tool balancer, light-weight design



With the help of the REMA spring balancers, electric and pneumatic tools can be operated with minimal weight and positioned at the correct height.

### Properties

- Aluminum body.
- Specially designed coil spring ensures a low-noise run.
- Adjustable load capacity (button).
- Carabiner attached.
- Extra safety suspension, for safety chain.
- Flexible stainless steel cable.
- Resistance-free and wear-resistant cable guide.
- Adjustable cable length.
- Insulated suspension system.
- Fixation at a point.

### Applications

- For working with small pneumatic and electric drills, screwdrivers, measuring instruments etc.

### Norm:

- EN12100-1/2, DIN-EN15112

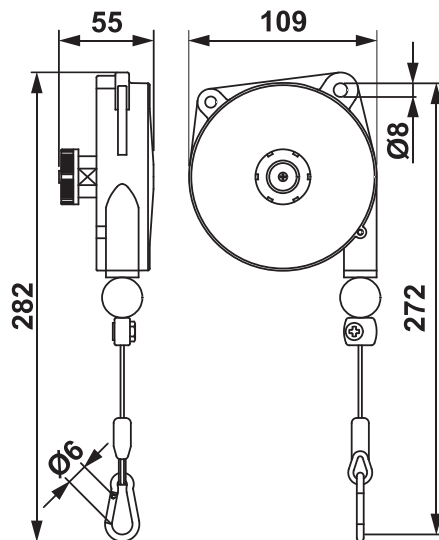

Type	WLL (kg)	Length (m)	Weight (kg)	ProductId
9311	0.4-1.0	1.6	0.6	0629311
9312	1.0-2.0	1.6	0.6	0629312
9313	2.0-3.0	1.6	0.7	0629313